

Isolated Doubler / Converter for RTD and resistance configurable by Dip-Switch or PC

DAT 4631 B

FEATURES

- Configurable input for RTD and resistance
- Double output configurable in current or voltage
- Configurable by dip-switch or PC
- High accuracy
- On-field reconfigurable
- Galvanic isolation among the ways
- UL / CE / UKCA mark
- Suitable for DIN rail mounting in compliance with EN-50022 and EN-50035



GENERAL DESCRIPTION

The isolated doubler/converter DAT 4631 B is able to measure and linearise the standard RTDs and resistances with 2 or 3 wires cable compensation. In function of programming, the measured values are converted in a current or voltage signal. The device guarantees high accuracy and performances stability both versus time and temperature.

The programming is made by the dip-switch located in the window on the side of the enclosure. By means of dip-switches it is possible to select the input type and range and the output type without recalibrate the device.

Moreover, by Personal Computer the user can program all of the device's parameters for his own necessity; the configuration by PC allows to program the two outputs with two independent settings. For all the sensors it is possible to set the cable compensation with 2 or 3 wires.

Moreover it is available the option of alarm for signal interruption (burn-out) that allows to set the output value as high or low out of scale.

The 1500 Vac galvanic isolation on all ways (input, outputs and power supply) eliminates the effects of all ground loops eventually existing and allows the use of the converter in heavy environmental conditions found in industrial applications.

The DAT 4631 B is in compliance with the Directive UL 61010-1 for US market and with the Directive CSA C22.2 No 61010-1 for the Canadian market.

It is housed in a plastic enclosure of 12.5 mm thickness suitable for DIN rail mounting in compliance with EN-50022 and EN-50035 standards.

USER INSTRUCTIONS

The connections must be made as shown in the section "Connections".

It is possible to configure the converter on field by dip-switch or Personal Computer as shown in the section "Programming". The configuration by dip-switches can be made also if the device is powered (note: after the configuration the device takes some seconds to provide the right output measure).

TECHNICAL SPECIFICATIONS (Typical at 25 °C and in nominal conditions)

INPUT				OUTPUT (2 CHANNELS)				GENERAL SPECIFICATIONS	
Input type	Min	Max	Span min	Output type	Min	Max	Span min		
RTD (2, 3 wires) Pt100 Pt1000 Ni100 Ni1000	-200°C	850°C	50°C	Current	0 mA	20 mA	4 mA	Power supply voltage	18 .. 30 Vdc
	-85°C	185°C	30°C	Voltage	0 V	10 V	1 V	Reverse polarity protection	60 Vdc max
RES. (2, 3 wires)	-60°C	180°C	50°C	Output resolution				Current consumption	55 mA max.
	-60°C	150°C	30°C	Current	± 7 uA			Voltage output	25 mA max.
	0 Ω	500 Ω	50 Ω	Voltage	± 4 mV			ISOLATION	
	0 Ω	2000 Ω	50 Ω	Burn-out values				Among all the ways	1500 Vac, 50 Hz, 1 min
				Max. output value	22 mA or 10.6 V			ENVIRONMENTAL CONDITIONS	
				Min. output value	0 mA or -0.6 V			Operative Temperature	-20°C .. +60°C
				Output load Resistance - Rload				UL Operative Temperature	-10°C .. +60°C
				Current output	< 500 Ω			Storage Temperature	-40°C .. +85°C
				Voltage output	> 10 KΩ			Humidity (not condensed)	0 .. 90 %
				Short circuit current	26 mA max.			Maximum Altitude	2000 m
				Response time (10÷ 90%)				Installation	Indoor
					about 500 ms			Category of installation	II
Accuracy (1)								Pollution Degree	2
RTD	the higher of ±0.1% and ±0.2°C							MECHANICAL SPECIFICATIONS	
Low Res.	the higher of ±0.1% and ±0.15 Ω							Material	Self-extinguish plastic
High Res.	the higher of ±0.2% and ± 1 Ω							IP Code	IP20
Linearity (1)								Wiring	wires with diameter 0.8±2.1 mm ² /AWG 14-18
RTD	± 0.1 % f.s.							Tightening Torque	0.8 N m
Sensor excitation current								Mounting	in compliance with DIN rail standard EN-50022 and EN-50035
RTD,Res	500 uA							Weight	about 90 g.
Line resistance influence (1)								CERTIFICATIONS	
RTD 3 wires	0.05%/Ω (50 Ω max balanced)							EMC (for the Industrial Environments)	
Thermal drift (1)								Immunity	EN 61000-6-2
Full scale	± 0.01% / °C							Emission	EN 61000-6-4
								UKCA (ref S.I. 2016 N°1091)	
								Immunity	BS EN 61000-6-2
								Emission	BS EN 61000-6-4
								UL	
								US Standard	UL 61010-1
								Canadian Standard	CSA C22.2 No 61010-1
								CCN	NRAQ/NRAQ7
								Typology	Open Type device
								Classification	Industrial Control Equipment
								File Number	E352854

(1)referred to the input Span (difference between max. and min.)

PROGRAMMING

CONFIGURATION BY DIP-SWITCHES

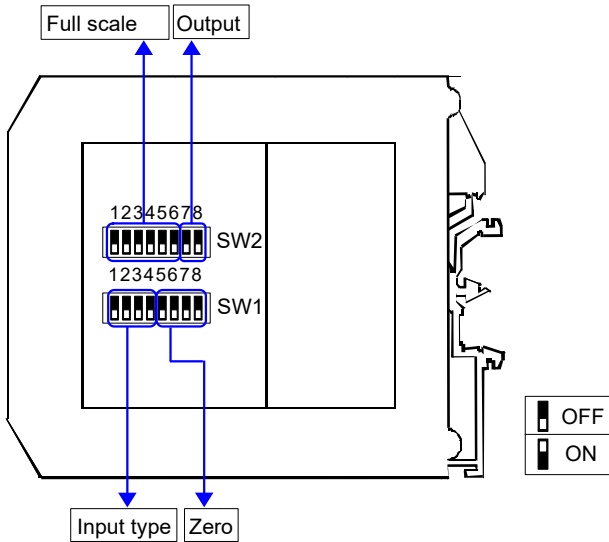

- 1) Open the suitable door on the side of the device.
- 2) Set the input type by the dip-switch SW1 [1..4] (see TAB.1)
- 3) Set the minimum input scale value (Zero) by the dip-switch SW1 [5..8] (see TAB.3)
- 4) Set the maximum input value (Full scale) by the dip-switch SW2 [1..6] (see TAB.3)
- 5) Set the output type by the dip-switch SW2 [7..8] (see TAB.2)

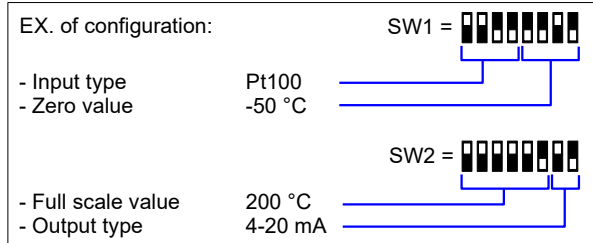

NOTE:

- It is also possible to set the dip-switches using the wizard of the configuration software following the procedure described in the section "Configuration by PC" until the step 6 and clicking on "Switch".

DIP-SWITCH CONFIGURATION TABLES

TAB.1
Input type settings

SW1	SW1
1 2 3 4	1 2 3 4
	EPROM *
	R 2KΩ
	R 500Ω
	Pt100
	Ni100
	Pt1000
	Ni1000

TAB.2
Output setting

SW2	
7 8	
	0-20 mA
	4-20 mA
	0-10 V
	0-5 V

NOTES:

- * For all the input types selected by dip-switches, the compensation of wires is fixed at 3. If the measurement is made by 2-wire RTD or resistor, it is necessary to make a short-circuit between the terminals G and L.
- * To configure the range for the input type selected (TAB.1) refer to the section of the TAB.3 on next page relative to it (ex: for Pt100 use the table TAB.3c).
- * If the dip-switches SW1 [1..4] are all set in the position 0 ("EPROM"), the device will follow the configuration programmed by PC (input type and range, output type and range and options).
- * If the dip-switches SW1 [5..8] are all set in the position 0 ("Default"), the device will follow the input scale programmed by PC for the input type selected by the dip-switches SW1 [1..4]
- * Eventual wrong dip-switches settings will be signaled by the blinking of the led "PWR".

CONFIGURATION BY PC

Notice: before to execute the next operations, check that the drivers of the cable CVPROG in use have been previously installed in the Personal Computer.

By software DATAPRO it is possible to:

- set the default programming of the device;
- program the options not available with the dip-switch; (burn-out level, CJC offset, trip alarm settings, delay on output, etc...);
- read, in real time, the input and output measures;
- follow the dip-switches configuration wizard.

To configure the device follow the next steps:

- 1) Open the protection plastic label on the front of the device.
- 2) Connect the two plugs of cable CVPROG to the Personal Computer (USB plug) and to the device (uUSB plug).
- 3) Run the software
- 4) Select the COM port in use and click on "Open COM".
- 5) Select the device and connect to it.
- 6) Set the programming data.
- 7) Click "Write" to send the programming data to the device.

For information about the software refer to its user guide.

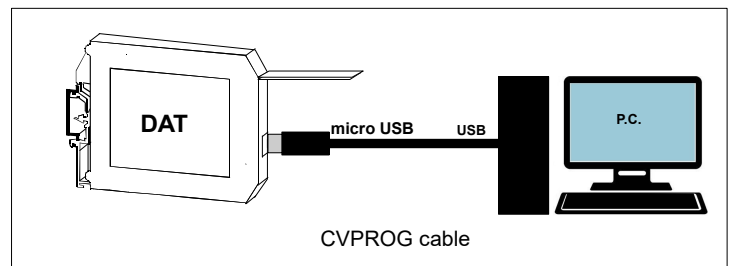

TAB.3a – Settings for Resistance < 2KOhm

Zero		Full scale							
SW1 5 6 7 8	Ω	SW2 1 2 3 4 5 6	Ω	SW2 1 2 3 4 5 6	Ω	SW2 1 2 3 4 5 6	Ω	SW2 1 2 3 4 5 6	Ω
	Default		Default		800		1150		1600
	0		500		820		1175		1650
	150		520		840		1200		1700
	200		540		860		1225		1750
	250		560		880		1250		1800
	300		580		900		1275		1850
	350		600		920		1300		1900
	400		620		940		1325		1950
	450		640		960		1350		2000
	500		660		980		1375		2000
	550		680		1000		1400		2000
	600		700		1025		1425		2000
	650		720		1050		1450		2000
	700		740		1075		1475		2000
	750		760		1100		1500		2000
	800		780		1125		1550		2000

TAB.3b – Settings for Resistance < 500 ohm

Zero		Full scale							
SW1 5 6 7 8	Ω	SW2 1 2 3 4 5 6	Ω	SW2 1 2 3 4 5 6	Ω	SW2 1 2 3 4 5 6	Ω	SW2 1 2 3 4 5 6	Ω
	Default		Default		125		210		370
	0		50		130		220		380
	10		55		135		230		390
	20		60		140		240		400
	30		65		145		250		410
	40		70		150		260		420
	50		75		155		270		430
	75		80		160		280		440
	100		85		165		290		450
	125		90		170		300		460
	150		95		175		310		470
	175		100		180		320		480
	200		105		185		330		490
	225		110		190		340		500
	250		115		195		350		500
	300		120		200		360		500

TAB.3c – Settings for Pt100, Pt1K, Ni100, Ni1K

Zero		Full scale							
SW1 5 6 7 8	°C	SW2 1 2 3 4 5 6	°C	SW2 1 2 3 4 5 6	°C	SW2 1 2 3 4 5 6	°C	SW2 1 2 3 4 5 6	°C
	Default		Default		75		210		370
	-200		0		80		220		380
	-150		5		85		230		390
	-100		10		90		240		400
	-50		15		95		250		425
	-40		20		100		260		450
	-30		25		110		270		475
	-20		30		120		280		500
	-10		35		130		290		525
	0		40		140		300		550
	5		45		150		310		600
	10		50		160		320		650
	20		55		170		330		700
	30		60		180		340		750
	50		65		190		350		800
	100		70		200		360		850

INSTALLATION INSTRUCTIONS

The device is suitable for fitting to DIN rails in the vertical position.
For optimum operation and long life follow these instructions:

When the devices are installed side by side it may be necessary to separate them by at least 5 mm in the following cases:

- If panel temperature exceeds 45°C.
- Use of high power supply value (> 27 Vdc).
- Use of output current.

Make sure that sufficient air flow is provided for the device avoiding to place raceways or other objects which could obstruct the ventilation slits. Moreover it is suggested to avoid that devices are mounted above appliances generating heat; their ideal place should be in the lower part of the panel.

Install the device in a place without vibrations.

Moreover it is suggested to avoid routing conductors near power signal cables (motors, induction ovens, inverters etc...) and to use shielded cable for connecting signals.

ISOLATION STRUCTURE

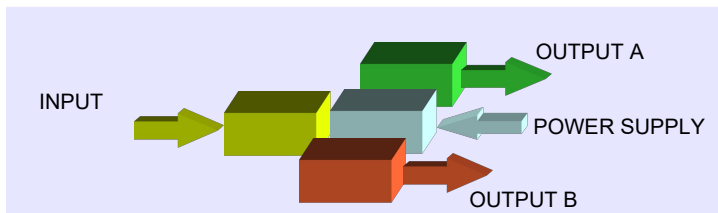

LIGHT SIGNALLING

LED	COLOUR	STATE	DESCRIPTION
PWR	GREEN	ON	Device powered
		OFF	Device not powered
		BLINKING	Wrong dip-switches setting

CONNECTIONS

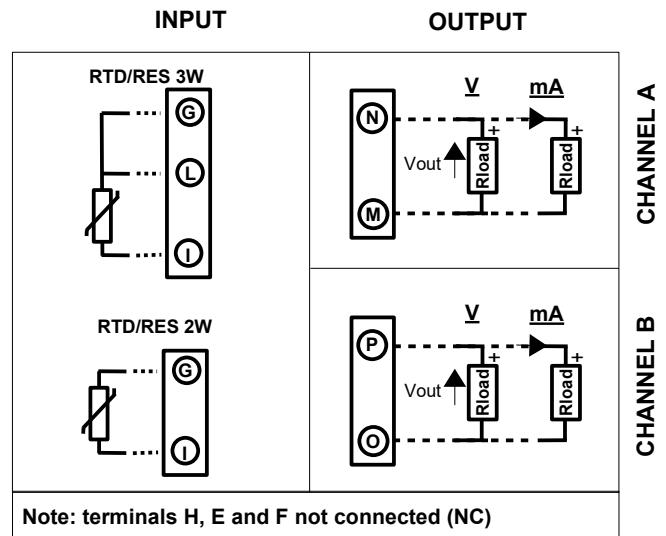

POWER SUPPLY(*)

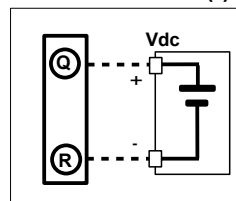

DIMENSIONS (mm)

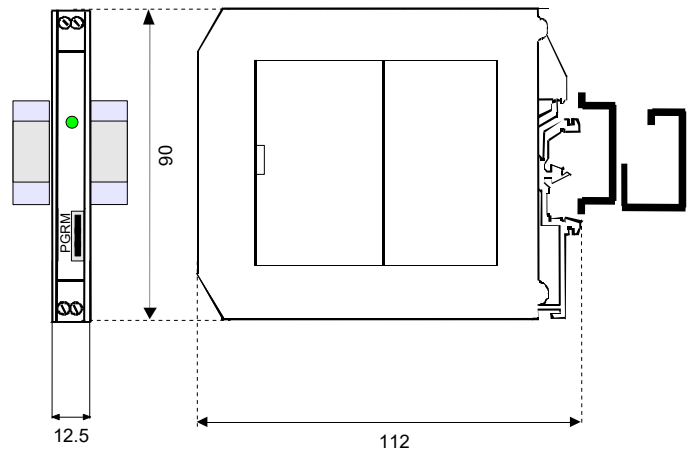

HOW TO ORDER

The device is provided as requested on the Customer's order.
Refer to the section "Programming" to determine the input and output ranges.
In case of the configuration is not specified, the parameters must be set by the user.

ORDER CODE EXAMPLE:

DAT 4631B / Pt100 / 0 ÷ 200 °C / 4 ÷ 20 mA / 3 wires

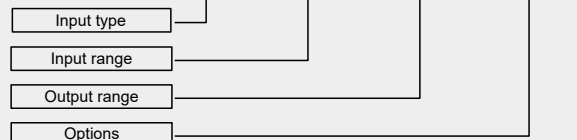

The symbol reported on the product indicates that the product itself must not be considered as a domestic waste. It must be brought to the authorized recycle plant for the recycling of electrical and electronic waste.
For more information contact the proper office in the user's city, the service for the waste treatment or the supplier from which the product has been purchased.